

# Analytically Accurate™

**MHR**

**DASTECS** S.R.L.

Representantes / Distribuidores Exclusivos

Buenos Aires, Argentina

Tel.: (54 - 11) 5352-2500

Email: info@dastecsrl.com.ar

Web: www.dastecsrl.com.ar

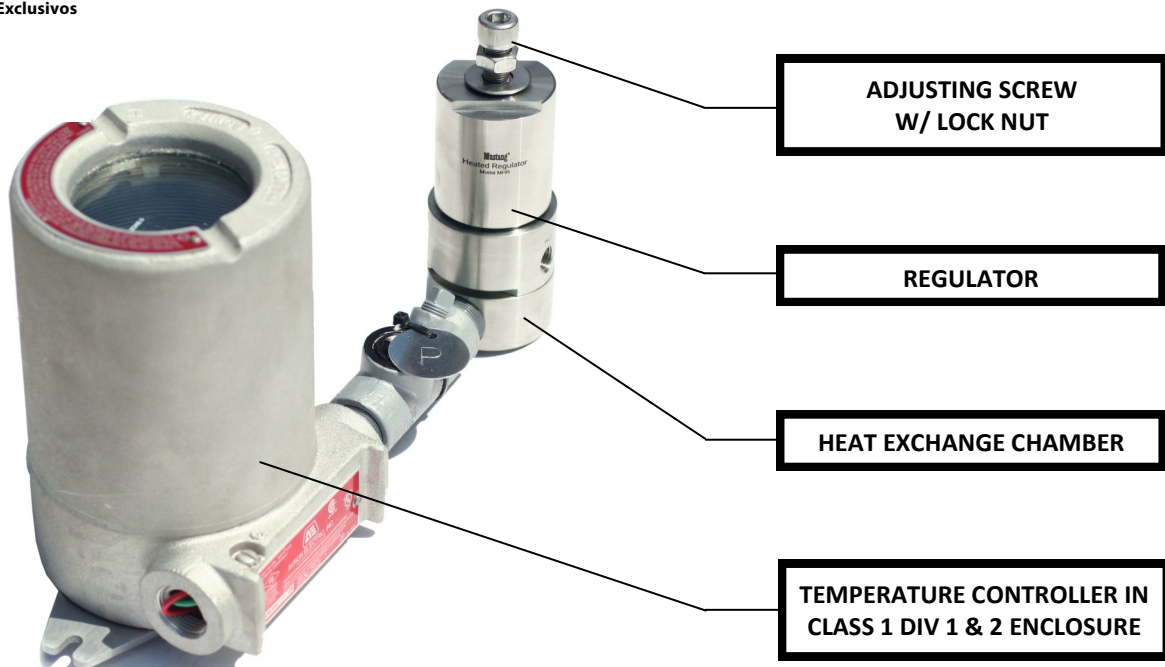

## Mustang® Heated Regulator

The Mustang® Heated Regulator (MHR) is designed to heat a gas sample to a customer specified temperature and pressure set point. Liquid condensation from a single-stage pressure reduction is prevented through a two-stage heating process.

The regulator body houses an electronically controlled thermistor and cartridge heater, precisely maintaining and measuring the gas sample. Through an innovative design comprised of a long, spiral flow path, the MHR eliminates the need of heating coils for efficient heat transfer and low maintenance.

The MHR assembly provides safe and reliable temperature control and pressure reduction essential to ensuring the performance of gas analyzers.

- ▶ Analytically Accurate™
- ▶ CRN Approved
- ▶ Provides continuous gas sample conditioning in any process industry
- ▶ Protects analyzers & helps preserve sample integrity
- ▶ Efficient heat transfer through pre-heat and post-heat chambers
- ▶ Proportional temperature control
- ▶ Thermal cutoff
- ▶ Contact us to determine heated and supercritical application needs with our Equations of State software

# PRODUCT DIMENSIONS

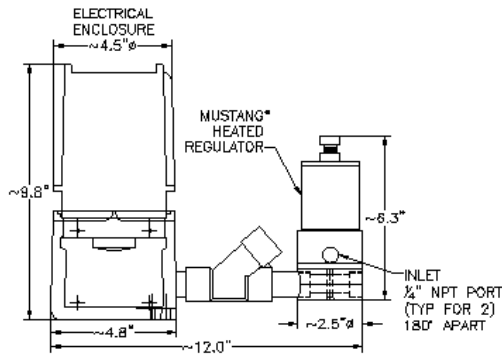

Fig. 1a—Side View

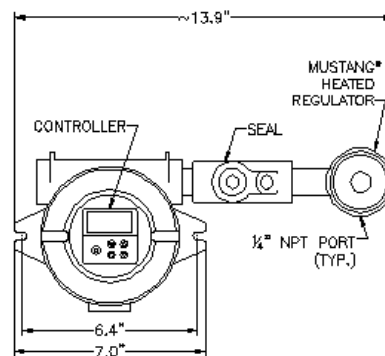

Fig. 1b—Top View

# PRODUCT SPECIFICATIONS

Maximum allowable working pressure	6000 psig (414 bar)
Proportional temperature control range	-15 °F (-26 °C) to 300 °F (149 °C) (other ranges available upon request)
Outlet pressure range	0-10, 0-25, 0-50, 0-100, 0-250, or 0-500 psig (0-0.69, 0-1.72, 0-3.45, 0-6.89, 0-17.24, or 0-34.47 bar)
Thermal cut-off	Normally opens at 230°F (110°C) [other ranges available—max. 400°F (204°C)]
Internal volume	5 cc
Cv Coefficient	0.06
Port sizes	1/4" female NPT
Conduit connection	1/2" NPT
Electrical enclosure classification	Class 1, Div 1 & 2, Groups B, C, D
Power rating options	115 VAC, 200 Watts, 50/60 Hz, ± 10% 208 VAC, 200 Watts, 50/60 Hz, ± 10% 230 VAC, 200 Watts, 50/60 Hz, ± 10% 24 VDC, 140 Watts
Wetted materials	Machined parts: 316 stainless steel/NACE compliant All other metal parts: stainless steel/NACE compliant Seat material: Teflon® (other materials available upon request)



**Mustang Sampling®**

info@mustangsampling.com  
www.mustangsampling.com

P 304-273-5357  
F 304-273-2531  
P.O. Box 490  
Ravenswood, WV 26164



MSBC-C-MHR VOL. 1 ©2009-2014 MUSTANG SAMPLING, LLC. ALL RIGHTS RESERVED.

Locally Represented By:

**DASTEC S.R.L.**

Representantes / Distribuidores Exclusivos

Buenos Aires, Argentina  
Tel.: (54 - 11) 5352-2500  
Email: info@dastecsr.com.ar  
Web: www.dastecsr.com.ar